

A ELEVATION/PLAN

- KEYNOTES:**
- 03-1 2" x 5-1/2" BOLT-IN FRAME: 12 GA. STEEL, PRIMED FINISH; UL LEVEL 8
 - 03-3 4-3/4" x 4" ANCHOR PLATE: 12 GA. STEEL, PRIMED FINISH
 - 03-4 1-1/4" x 1-1/4" REMOVABLE STOP: 12 GA. STEEL, PRIMED FINISH
 - 03-14 UL LEVEL 8 GLAZING
 - 03-17 GLAZING TAPE (SUPPLIED) AND SEALANT (BY OTHERS)
 - 03-20 MOUNTING SCREW
 - 01-3 TYPICAL WALL CONSTRUCTION (BY OTHERS)
 - 01-4 ANCHOR, AS REQUIRED (BY OTHERS)
 - 01-5 BULLET-RESISTANT ARMOR, UL LEVEL 8

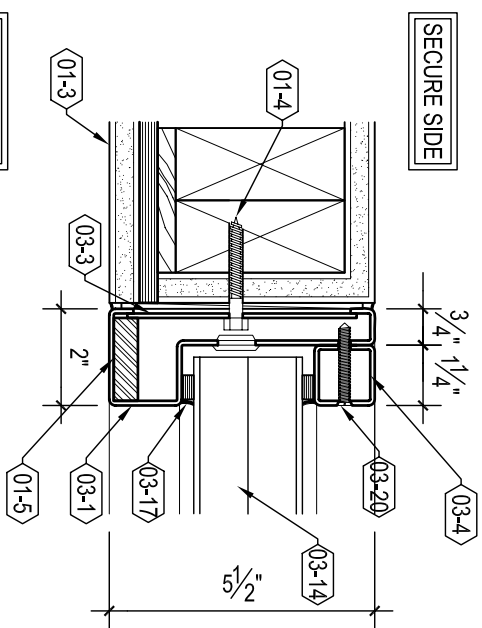

B JAMB DETAIL 1

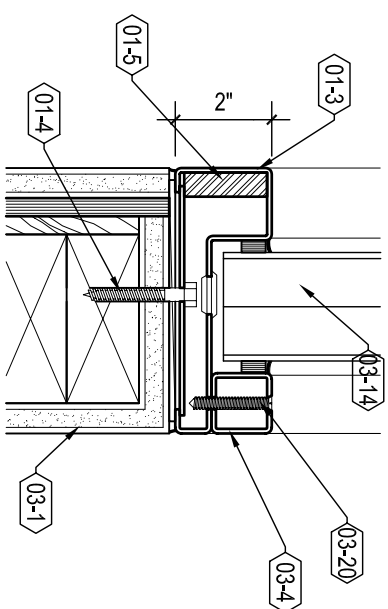

C SILL DETAIL

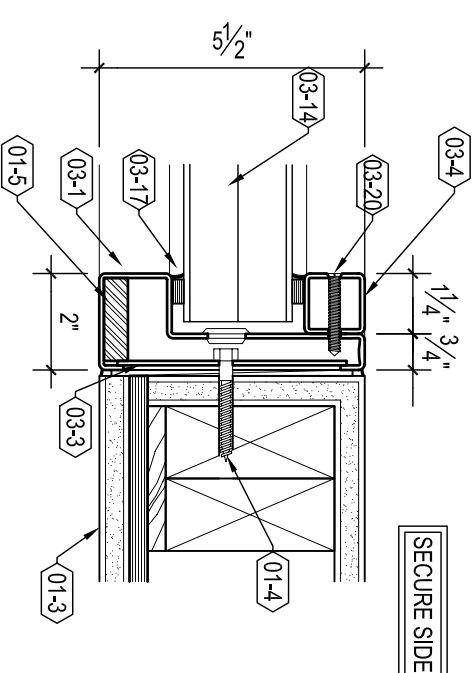

D JAMB DETAIL 2

NORTH AMERICAN BULLET PROOF
 NABP
 P.O. BOX 628
 106 GUADALUPE DRIVE
 CIBOLO TX, 78108
 PHONE # (210) 225-0982
 FAX # (210) 225-0984
 WEBSITE: www.nabulleproof.com

ALL RIGHTS RESERVED:
 THIS DRAWING IS THE PROPERTY OF NORTH AMERICAN BULLET PROOF AND SHALL NOT BE REPRODUCED IN WHOLE OR PART. IT SHALL NOT BE USED FOR CONSTRUCTION OF OTHER THAN THE SPECIFIED PROJECT WITHOUT WRITTEN PERMISSION OF NORTH AMERICAN BULLET PROOF.

COMMENTS:

EXVW8-P-BF