

**KEYNOTES:**

- ⓪3-1 2" x 5-1/2" BOLT-IN FRAME: 14 GA. STAINLESS STEEL; UL LEVEL 1
- ⓪3-3 4-3/4" x 4" ANCHOR PLATE: 14 GA. STAINLESS STEEL
- ⓪3-4 1-1/4" x 1-1/4" REMOVABLE STOP: 14 GA. STAINLESS STEEL
- ⓪3-14 UL LEVEL 1 GLAZING
- ⓪3-17 GLAZING TAPE (SUPPLIED) AND SEALANT (BY OTHERS)
- ⓪3-20 MOUNTING SCREW
- ⓪1-3 TYPICAL WALL CONSTRUCTION (BY OTHERS)
- ⓪1-4 ANCHOR, AS REQUIRED (BY OTHERS)

**NORTH AMERICAN**  
BULLET PROOF  
NABP  
P.O. BOX 628  
106 GUADALUPE DRIVE  
CIBOLO TX, 78108  
PHONE # (210) 225-0982  
FAX # (210) 225-0984  
WEBSITE: www.nabulleproof.com

ALL RIGHTS RESERVED:

THIS DRAWING IS THE PROPERTY OF NORTH AMERICAN BULLET PROOF AND SHALL NOT BE REPRODUCED IN WHOLE OR PART. IT SHALL NOT BE USED FOR CONSTRUCTION OF OTHER THAN THE SPECIFIED PROJECT WITHOUT WRITTEN PERMISSION OF NORTH AMERICAN BULLET PROOF.

COMMENTS:

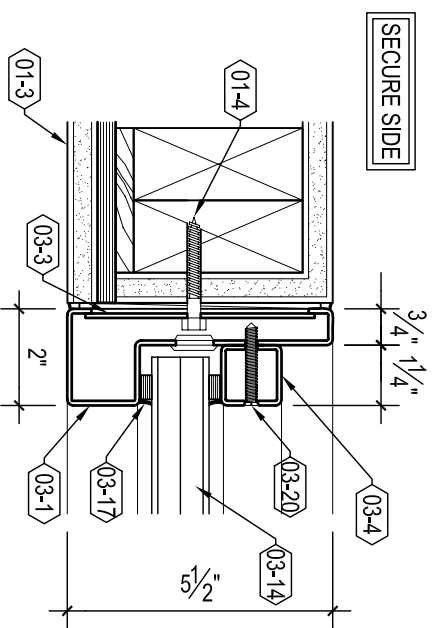

**B** JAMB DETAIL 1

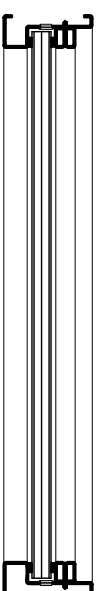

**A** ELEVATION/PLAN

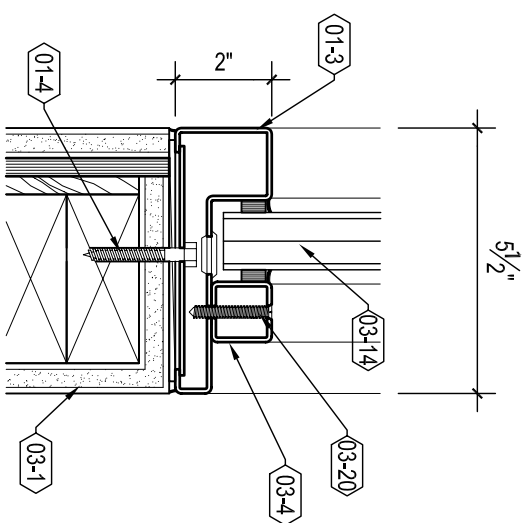

**C** SILL DETAIL

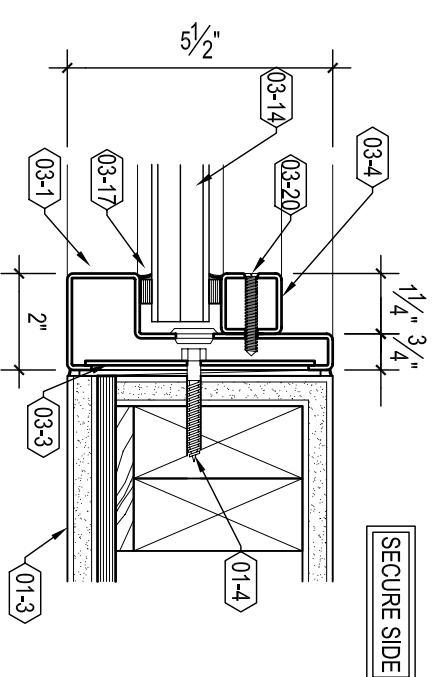

**D** JAMB DETAIL 2

EXVW1-SS-BF